

# MAXIM

## MAX4299 Evaluation Kit

**Evaluates: MAX4299**

### General Description

The MAX4299 evaluation kit (EV kit) is a fully assembled and tested circuit board that uses the MAX4299 audio system IC designed for a single 5V application. The audio system IC features a stereo headphone driver, microphone amplifier, and a 3.3V linear regulator.

The EV kit's headphone driver is capable of driving 1.2V<sub>RMS</sub> into a 32Ω headphone. The microphone amplifier is capable of driving 1.5V<sub>RMS</sub> into a 10kΩ load. A 3.3V linear regulator is capable of supplying 100mA.

### Component Suppliers

SUPPLIER	PHONE	FAX
AVX	843-448-9411	843-448-1943
Central Semiconductor	631-435-1110	631-435-1824
Taiyo Yuden	800-348-2496	847-925-0899

**Note:** Please indicate that you are using the MAX4299 when contacting these component suppliers.

DESIGNATION	QTY	DESCRIPTION
C1, C10	2	10μF, 6.3V X5R ceramic capacitors (1206) Taiyo Yuden JMK316BJ106ML
C2, C3, C6	3	0.33μF, 10V X5R ceramic capacitors (0603) Taiyo Yuden LMK107BJ334KA
C4, C5, C12	3	1μF, 6.3V X5R ceramic capacitors (0603) Taiyo Yuden JMK107BJ105KA
C7, C8, C9	3	220μF, 6.3V tantalum capacitors (Case C) AVX TAJC227K006
C11	1	0.1μF, 16V X7R ceramic capacitor (0603) Taiyo Yuden EMK107BJ104KA
D1	1	0.2A, 30V super-mini Schottky-diode (SOD-323) Central Semiconductor CMDSH2-3

### Features

- ◆ 4.5V to 5.5V Single-Supply Operation
- ◆ Clickless/Popless Power-Up, Power-Down, Mute and Unmute
- ◆ PC99-Compliant Output Drivers:  
Better than 1.2V<sub>RMS</sub> Output into 32Ω Audio Load
- ◆ PC99-Compliant Microphone Amplifier:  
Better than 1.5V<sub>RMS</sub> Output into 10kΩ Load
- ◆ Small 16-Pin TSSOP Package
- ◆ Fully Assembled and Tested

### Ordering Information

PART	TEMP RANGE	IC PACKAGE
MAX4299EVKIT	0°C to +70°C	16 TSSOP

### Component List

DESIGNATION	QTY	DESCRIPTION
J1	1	Right-angle phono jack (white)
J2	1	Right-angle phono jack (red)
J3	1	Right-angle phono jack (yellow)
J4, J5	2	3.5mm stereo jacks
R1, R4, R5, R6, R8	5	20kΩ ±1% resistors (0805)
R2, R3	0	Not installed (0805)
R7	1	200kΩ ±1% resistor (0805)
R9	1	2kΩ ±1% resistor (0805)
R10, R11, R12	3	100kΩ ±5% resistors (0805)
JU1	1	2-pin header
JU2	1	3-pin header
None	2	Shunts (JU1, JU2)
None	1	MAX4299 PC board
None	1	MAX4299 data sheet
None	1	MAX4299 EV kit data sheet
U1	1	MAX4299EUE, 16-pin TSSOP

# MAX4299 Evaluation Kit

## Quick Start

The MAX4299 EV kit is fully assembled and tested. Follow these steps to verify board operation. **Do not turn on the power supply until all connections are completed.**

### Recommended Equipment

- 5V, 1A power supply
- Stereo headphone with 3.5mm plug
- Microphone
- Audio source
- One voltmeter

### AVDD Output

- 1) Connect the positive lead of the voltmeter to the AVDD pad, and the negative lead of the voltmeter to the GND pad.
- 2) Connect the 5V of the power supply to the VCC pad and the power supply ground to the PGND pad.
- 3) Turn on the power supply, and set the output of the power supply to 5V.
- 4) Verify that the AVDD pad is approximately 3.3V.

### Headphone Drivers

- 1) Verify that Jumper JU1 does not have a shunt installed.
- 2) Verify that Jumper JU2 has a shunt across pins 2 and 3.
- 3) Connect an audio source to jacks J1 (left) and J3 (right).
- 4) Connect the stereo headphone to the J5 jack.
- 5) Turn on the audio source.

### Microphone Amplifier

- 1) Verify that Jumper JU1 does not have a shunt installed.
- 2) Verify that Jumper JU2 has a shunt across pins 2 and 3.
- 3) Connect a microphone to the MICIN jack J4.
- 4) Remove the audio source from jacks J1 and J3, and connect the MICOUT jack (J2) to J1.
- 5) Connect a stereo headphone to jack J5 (headphone out).

- 6) Speak into the microphone and detect the audio signal with the headphone (left channel only).

## Detailed Description

The MAX4299 EV kit uses a MAX4299 audio system IC designed for 5V applications. The audio system IC features a stereo headphone driver, a microphone amplifier, and a 3.3V linear regulator. In addition, the EV kit also includes a mute function and a standby power-supply (SVCC) pad for the user.

The MAX4299 EV kit is configured to receive two audio sources (left and right). The two audio sources are current-amplified (unity-voltage gain) to drive up to 1.2V<sub>RMS</sub> into a 32Ω stereo headphone. The microphone amplifier has voltage gain of -10V/V and is capable of driving 1.5V<sub>RMS</sub> into a 10kΩ load. The 3.3V linear regulator is capable of supplying up to 100mA. Resistors R2 and R3 may be added to adjust the output of the linear regulator between 1.2V and 4.5V. Refer to the *Regulator* section of the MAX4299 data sheet.

### Jumper Selection

#### Mute

Jumper JU1 controls the mute pin (MUTE) on the MAX4299 IC. Mute is a clickless function that turns off the headphone without having to power-down the whole system. The mute function may be activated on the EV kit by installing a shunt across pins 1 and 2 of jumper JU1. The mute function may also be controlled by an external source connected to the MUTE pad and removing the shunt on jumper JU1. See Table 1 for shunt positions.

#### Standby Power Supply

Jumper JU2 selects between an external standby power supply (SVCC) or the on-board SVCC. The standby power-supply pin (SVCC) draws a small amount of reserve power to drive a clickless/popless power-down sequence. The reserve power for SVCC can be stored in the capacitor C9. Capacitor C9 is charged by VCC through Schottky diode D1. The SVCC pin can also be powered by an external source connecting to the SVCC pad and reconfiguring jumper JU2. (See Table 2 for shunt positions.)

# MAX4299 Evaluation Kit

Evaluates: MAX4299

Table 1. JU1 Jumper Selection

JUMPER	JUMPER POSITION	EV KIT FUNCTION
JU1	Installed (MUTE = high)	Mute enabled
	None (MUTE = low)	Mute disabled
	None. External source connected to MUTE pad.	MUTE driven by external source. Mute is active high.

Table 2. JU2 Jumper Selection

JUMPER	JUMPER POSITION	EV KIT FUNCTION
JU2	1-2	SVCC pin powered by external source (4.5V to 5.5V)
	2-3	SVCC pin powered by VCC pad through D1
	None	SVCC is not powered. Clickless/Popless disabled.

# MAX4299 Evaluation Kit

Evaluates: MAX4299

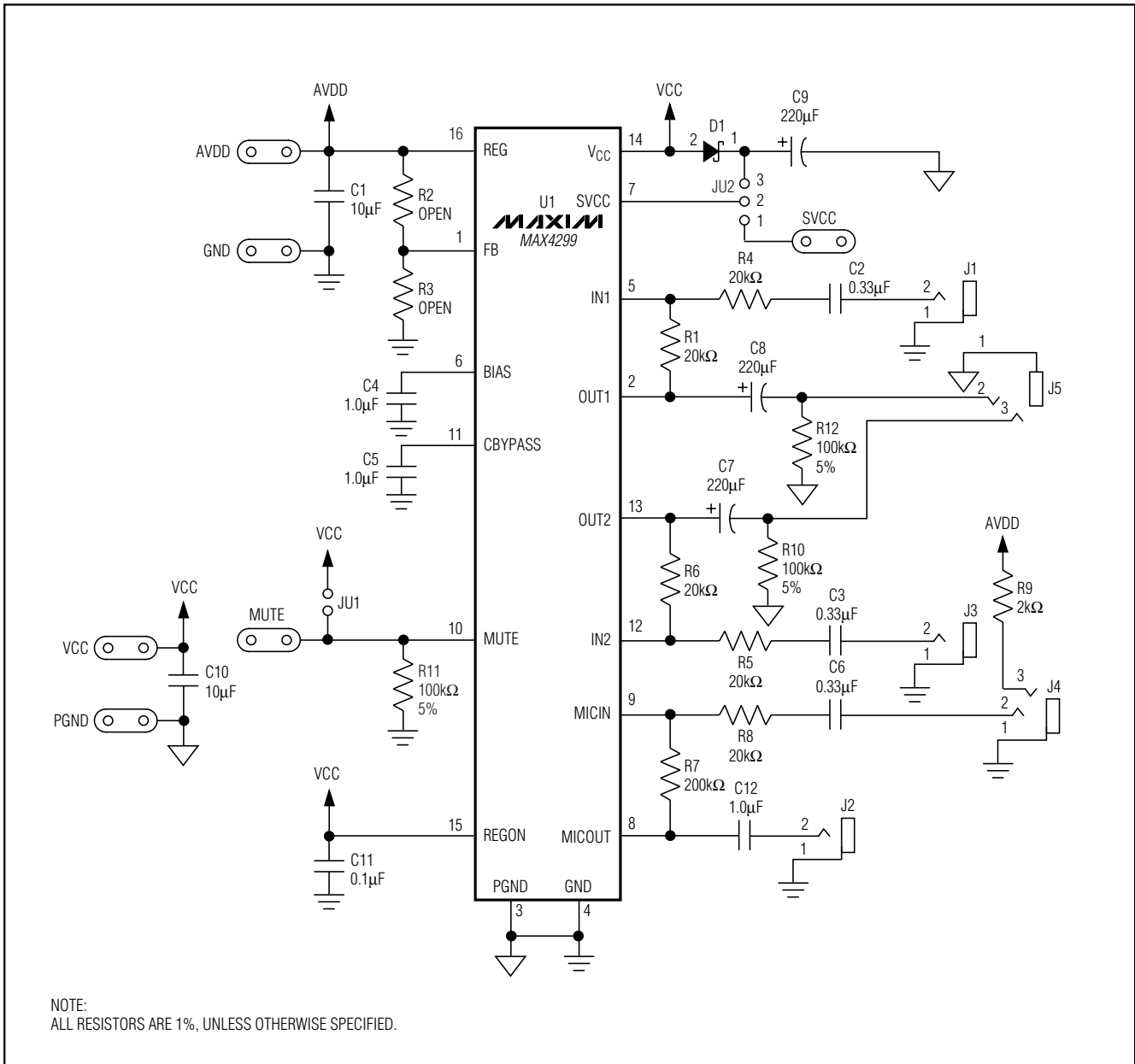

Figure 1. MAX4299 EV Kit Schematic

# MAX4299 Evaluation Kit

Evaluates: MAX4299

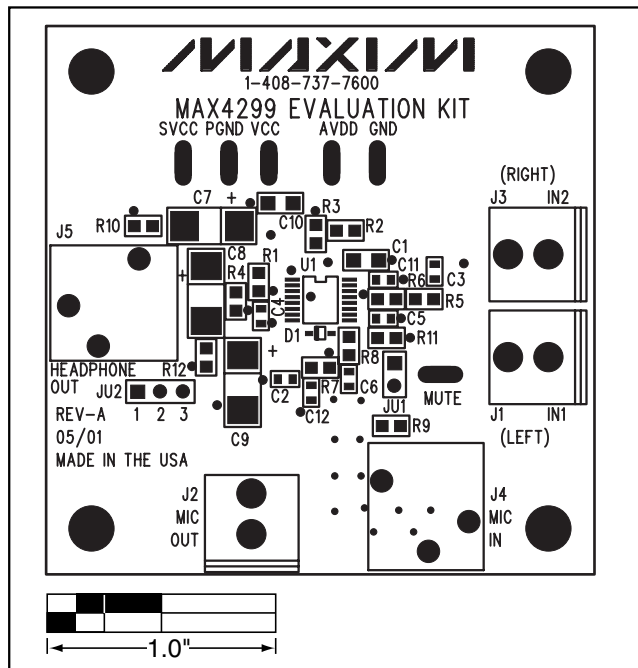

Figure 2. MAX4299 EV Kit Component Placement Guide—Component Side

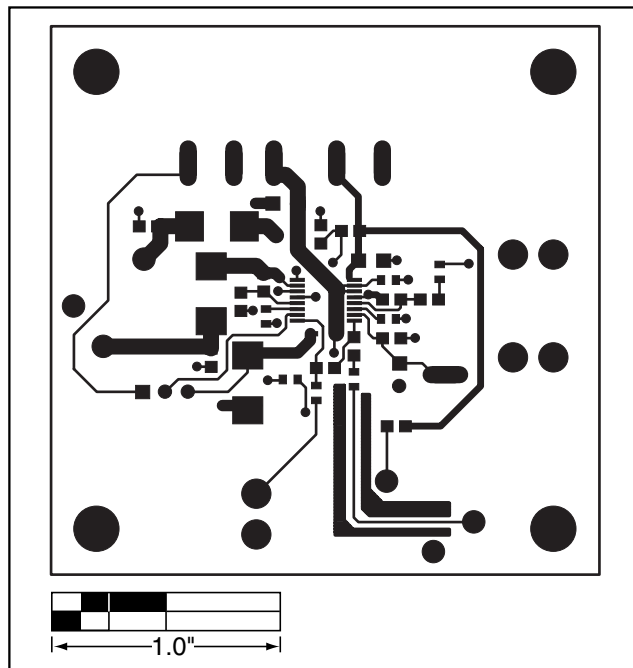

Figure 3. MAX4299 EV Kit PC Board Layout—Component Side

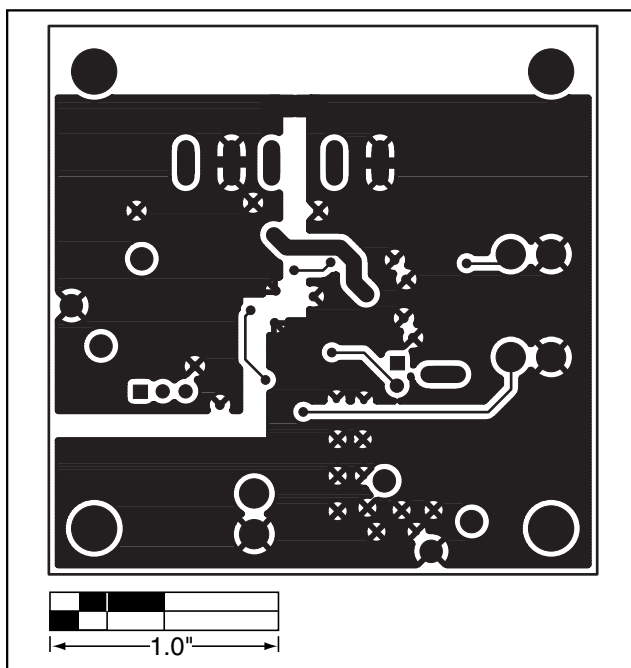

Figure 4. MAX4299 EV Kit PC Board Layout—Solder Side

Maxim cannot assume responsibility for use of any circuitry other than circuitry entirely embodied in a Maxim product. No circuit patent licenses are implied. Maxim reserves the right to change the circuitry and specifications without notice at any time.

Maxim Integrated Products, 120 San Gabriel Drive, Sunnyvale, CA 94086 408-737-7600 \_\_\_\_\_ 5